

# HIGH PERFORMANCE INJECTING TECHNOLOGY

M2 INJECTORS / CONSISTENCY / ACCURACY / DELIVERED!

# THE M2 INJECTOR HIGH PERFORMANCE INJECTING TECHNOLOGY

The Fomaco M2 injector is a sturdy, extremely durable, high performance machine designed to work in a highly demanding and aggressive production environment.

The M2 is not only reliable but requires a minimum of maintenance.

With the M2 you will be able to handle all meat types, both bone-in and boneless, and at the same time meet the demand for low and high injection levels.



Serving the  
food industry  
for 40 years



## ACCURATE INJECTION MINIMAL RETURN BRINE

The M2 activates the needle head valves individually, injecting only when the needles are in the product, thus reducing the amount of return brine or marinade considerably.



## MAXIMUM CONTROL

The sectionally divided stripper feet follow the contours of the product and prevent the product from moving when the needles are retracted. This also provides a uniform needle pattern and prevents the product from being injected twice – or from not being injected at all.



## CONSISTENT BRINE DISTRIBUTION

The high performance centrifugal pump gives a constant brine pressure, ensuring a uniform distribution of brine - regardless of product size and number of needles in the product.



## NO BLOCKED NEEDLES

The standard M2 injector comes with an F-80 cartridge type filter. However, you can upgrade to the FM 80 - a fully self-cleaning protein filter uniquely designed to remove all impurities in the brine, preventing the fine needle holes from blocking. This also ensures an even brine distribution, thus improving the product quality overall.

# SAFETY AND HYGIENE IS OUR NUMBER ONE PRIORITY

To ensure the highest hygiene level, the M2 series is both hygienic in production and easy to clean. All components are designed to match the liquid flow rate accurately throughout the system, preventing brine residues from settling in the brine system.

The brine tank is available with an optional cooling system that enables full temperature control. Combined with the monitoring of temperature from the control panel, the bacteriological growth is kept at a minimum.

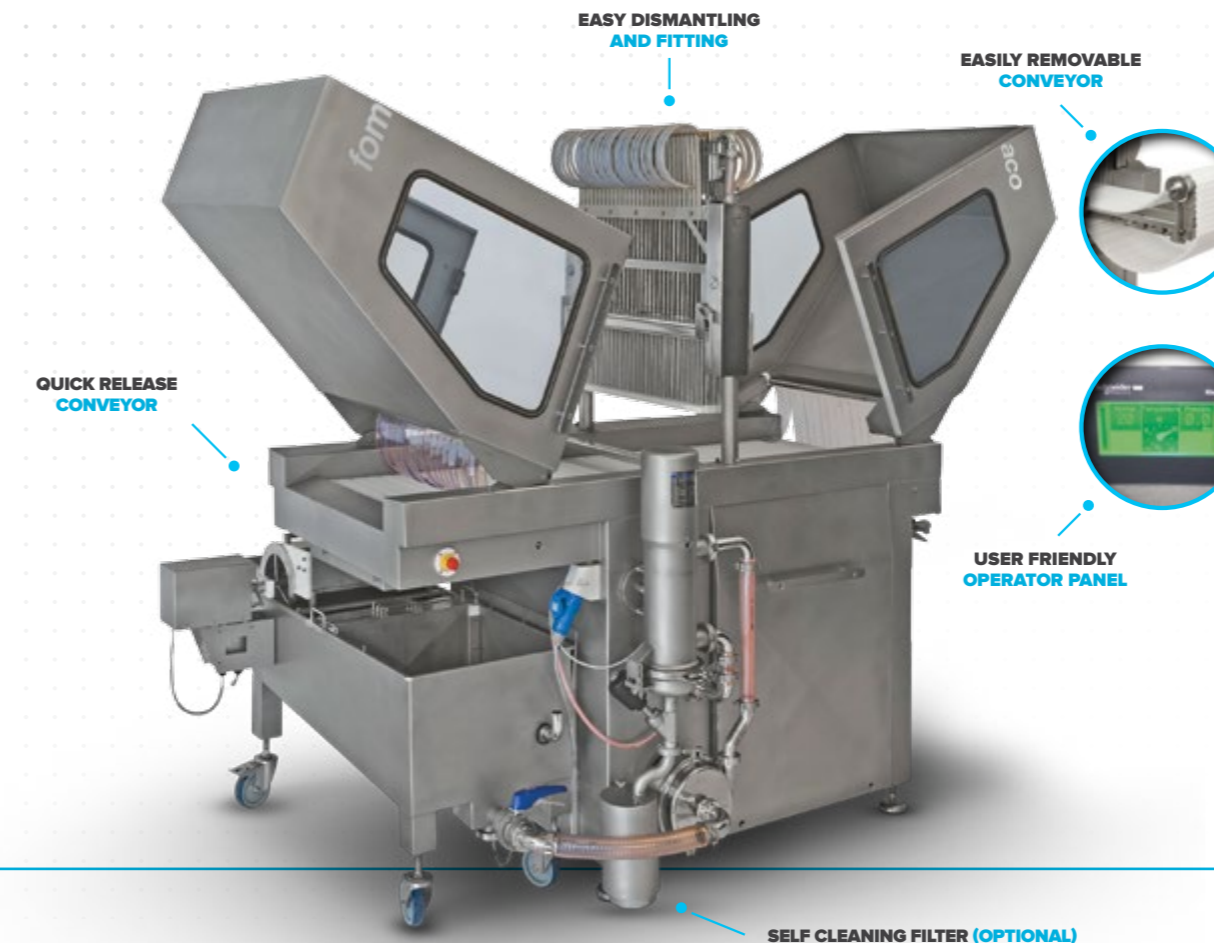

## CLEANING MADE EASY

Due to a number of special features the cleaning of the M2 series is both thorough and quick:

- Everything is manufactured in stainless steel and food approved plastic materials.
- All electrical components are fully protected in a separate cabinet with an IP 68 protection so special care is not needed when cleaning the machine.
- Needles can be dismantled and fitted without using tools.
- The conveyor is easily removed without using tools and a separate washing rack is available. The conveyor frame itself has a quick-release system for easy cleaning.



## USER FRIENDLY OPERATOR PANEL

Intuitive settings of pump pressure and production speed together with a constant read-out of brine temperature allows for precise and optimum food production.



## CONFIGURATION OPTIONS FOR RED MEAT INJECTORS

The M2 series offers various sizes of injectors depending on width of the transport systems (350 mm, 575 mm, and 700 mm). The injectors are available with 26, 44, or 54 needle sockets, mounted with either single, double or quadro needles.

For more information on configuration and technical specifications, please visit [www.fomaco.com](http://www.fomaco.com)

RED MEAT



# TECHNICAL SPECIFICATIONS

	FGM 26 M2	FGM 44 M2	FGM 54 M2
<b>Number of needles</b>	26 single, double or quadro	44 single, double or quadro	54 single, double or quadro
<b>Needle head</b>	20-90 Strokes per min.	20-90 Strokes per min.	20-90 Strokes per min.
<b>Transport system</b>	Conveyor belt - stainless steel or plastic (PEHD, Intralox)	Conveyor belt - stainless steel or plastic (PEHD, Intralox)	Conveyor belt - stainless steel or plastic (PEHD, Intralox)
<b>Transport system (width)</b>	350 mm	575 mm	700 mm
<b>Product movement</b>	30 mm and 50 mm per stroke	30 mm and 50 mm per stroke	30 mm and 50 mm per stroke
<b>Stroke height (max)</b>	230 mm	230 mm	230 mm
<b>Product height (max)</b>	200 mm	200 mm	200 mm
<b>Weight</b>	700 kg	780 kg	850 kg

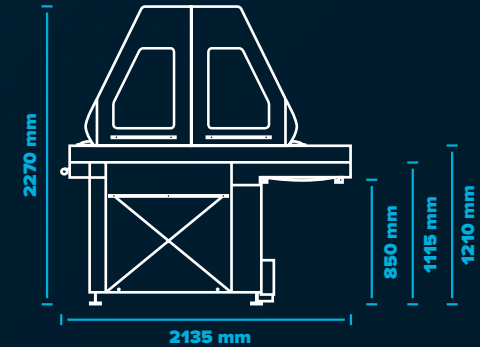

FGM 26 M2 **965 mm**  
 FGM 44 M2 **1275 mm**  
 FGM 54 M2 **1315 mm**

